

AXiA EX

SIT-ON STACKERS

1.6 – 2.0 - tonnes

GIANT PERFORMANCE COMPACT PACKAGE

The **AXiA EX** sit-on stacker is a flexible and cost-effective choice for stacking and internal transport in warehousing, manufacturing, and anywhere else safe, productive stacking is required. Platform stackers are more commonly used for these tasks but with an aisle width (AST) requirement of 2.8m (vs 2.5m on the AXiA EX) and lift heights of only 5.4m (vs 7m for the AXiA EX), it's easy to see where the sit-on stacker presents an opportunity to make much better use of space. Many companies use reach trucks for stacking tasks, but they may be over specified for the task. For these jobs the AXiA sit-on stacker makes an excellent low-cost alternative.

SPECIFICATIONS

SBS16N2
SBS16N2I
SBS20N2
SBS20N2I

**WHEN
RELIABILITY IS
EVERYTHING...**

SBS16-20N2 Series



AXiA EX

SBS16-20N2 Series

SIT-ON STACKERS

1.6 – 2.0 - tonnes



BRAKES

- **High-efficiency regenerative braking**
This gives more effective control and reduces brake wear.

DRIVE

- **Powerful AC drive motor**
High torque for greater efficiency. No carbon brushes mean lower servicing requirements.
- **Intelligent Cornering System**
The truck senses the angle of a turn and reduces speed early for maximum stability and accurate, positive cornering.
- **Automatic Speed Reduction**
Drive speed is automatically limited when forks are above 1.7m to allow higher capacities above that height.
- **High travel speeds**
Boosted productivity with optional top speed of up to 12 km/h (Load trailing).

ELECTRICAL AND CONTROL SYSTEMS

- **Built-in Li-ion battery**
Fast opportune charging removes the need for extra batteries and allows 24/7 operation. (Junior chassis only)
- **Convenient charging**
An extra battery plug on the outside of the truck allows for easy charging without needing to disconnect the internal battery plug. (Lead acid batteries).

Combi controller lift system

Fingertip control for speed regulated lifting and proportional valve for lowering.

Enhanced Stability System (ESS)

4-point chassis for maximum stability, drive speed is reduced when forks are lifted over 1.7m, and acceleration is reduced when steering angle exceeds 45 degrees.

FORKS AND MAST

Tapered and angled fork tips

Access to pallets is easier, quicker and safer.

Level Assistance System

Automatically detects the operator's intention and automatically stops when the forks are at precisely at the right level. (Option)

Laser positioning guide

Aligning the red laser with rack markings allows the driver to quickly ensure the forks are central to the desired position. (Option)

Initial Lift

Can be used as a double pallet handler. (Option on (i) models only)

FRAME AND BODY

Robust chassis

Built for intensive operations, with great inherent strength and high residual capacities. Designed to enclose the operator within for extra safety.

Strong battery lock

Simple and safe. Battery lock can only be unlocked when battery plug is disconnected. Battery plug can only be reconnected if battery is locked.

Excellent ground clearance

Easy and safe handling on loading docks and ramps.

RapidAccess features

These allow quick and easy entry to all areas for checks and maintenance.

Waterproof wiring and connectors

Sealed compartment prevents system failure and corrosion from water and dust.

Overhead guard pillars

Protection for the operator while still offering excellent visibility.

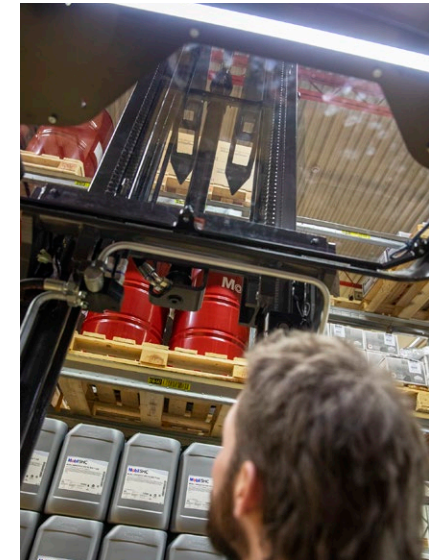
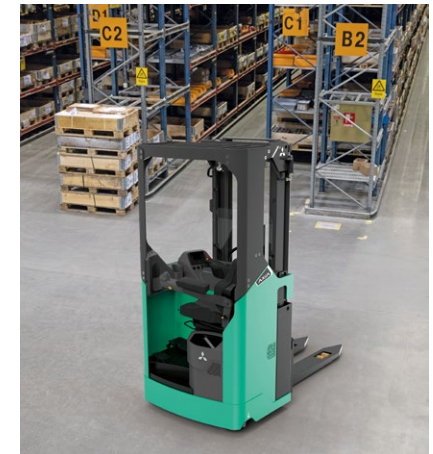

For more information
on AXiA EX sit-on
please visit our website



mft2.eu/axiaexbs

AXiA EX

SBS16-20N2 Series

SIT-ON STACKERS

1.6 – 2.0 - tonnes

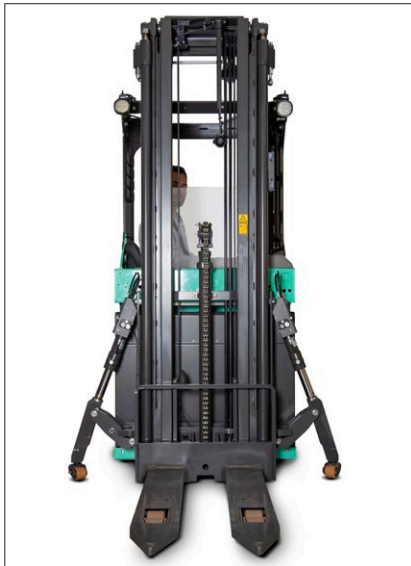

HYDRAULICS

- **Smooth, quick lifting and lowering**
High levels of control and productivity. Low noise means less fatigue for the operator over long shifts.
- **Mast damping**
Soft landing and seamless transition in the mast stages provides low noise and vibrations when lifting or lowering.

OPERATOR COMPARTMENT AND CONTROLS

- **Comfortable seat**
Adjustable so drivers can find their ideal working position for less fatigue over long shifts.
- **Plenty of storage space**
Storage for on-board essentials, putting clipboard, mobile phone, drinks bottle and pen all within easy reach.
- **Ultra-low step height**
Operators stay more productive throughout shifts thanks to easy on/off access.
- **Direction switch on handle**
Alternative for drivers who prefer hand control rather than direction control on a pedal. Standard with cold storage modification or 360-degree steering. (Option)
- **Temperature controlled fans**
Low noise for a more comfortable working environment.
- **Adjustable floor height**
More adaptable working position to suit a wide range of operator heights.

STEERING SYSTEM

- **Mini steering wheel with floating armrest**
Fully ergonomically adjustable, its unique design allows the operator to adopt a more relaxed and natural driving position. This reduces arm and shoulder strain and lowers the risk of RSI.
- **360-degree steering**
The operator can keep the truck in constant motion - saving seconds on every turn. (Option)
- **Dynamic Power Steering**
Smooth, precise control with minimum effort offering maximum comfort and stability at top speed.



For more information
on AXiA EX sit-on
please visit our website





AXIA EX OPTIONAL LI-ION BATTERY SYSTEMS

MAKE YOUR FORKLIFT GO EVEN FURTHER



Tried, tested and proven in the field, lead-acid batteries have been the long-standing choice for companies employing electric lift trucks. However, with long charging times, demanding maintenance requirements, the need for extra batteries, and high risk of operator misuse, day-to-day use can be a challenge.

Fortunately, there's a new battery system on the block: Li-ion from Mitsubishi Forklift Trucks.

Designed to meet your business' demands — including multi-shift (24/7) operations — without the need for spare batteries, our high-performance Li-ion battery system is up to 30% more efficient than lead-acid counterparts. Plus, it's virtually error-proof, thanks to its ultra-low-maintenance design which prevents cell damage.

- **Gas-emission free**
No need for air ventilation.

- **Exceptional high battery and charger efficiency**
State-of-the-art technology delivers up to 30% more power efficiency than lead-acid batteries.
- **Maintenance-free design**
No need for daily checks and water re-fills. This reduces the risk of operators damaging cells and reducing their lifetime. Needs a full charge each week to activate cell balancing.
- **No need for spare batteries or charging room**
You can save both space and costs in multi-shift applications, maximising profitability.
- **Quick charge capabilities**
Just 15 minutes is all your battery needs to keep your truck going for a few more hours. It only takes 1 to 2 hours to fully charge a completely discharged battery.

- **Higher sustained voltage**
This gives more consistent lifting and driving performance — particularly noticeable towards the end of a shift.
- **Multiple safety features**
This includes circuit protection, deep-discharge and overcharge protection, and individual cell temperature and voltage monitoring.
- **On-the-go performance and monitoring**
The system's integrated monitoring system has an easy-to-read display unit.
- **Wide choice of battery and charger capacities**
The most suitable power supply can be matched to the exact requirements of a specific application.



Li-ion battery option is available in selected regions.
Continuing improvement may lead to changes in these specifications

Clean Li-ion batteries are ideal for sensitive environments such as those in the food or packaging industries.

Fully integrated Li-ion battery

Features a sophisticated CANbus communication and an automatic ON/OFF synchronization between battery and truck. Battery level, notifications and alarms are integrated into the truck display, to secure clear and easy overview for the truck operator.

For more information on Li-ion please visit our website

mft2.eu/ion

VDI - PERFORMANCE & DIMENSIONS

CHARACTERISTICS				Mitsubishi Forklift Trucks	Mitsubishi Forklift Trucks
1.1	Manufacturer			Mitsubishi Forklift Trucks	Mitsubishi Forklift Trucks
1.2	Manufacturer's model designation			SBS16N2	SBS20N2
1.3	Power source			Battery	Battery
1.4	Operator type			Sit-on	Sit-on
1.5	Load capacity	Q	kg	1600	2000
1.6	Load center distance	c	mm	600	600
1.8	Load wheel axle to fork face (forks lowered)	x	mm	800	800
1.9	Wheelbase	y	mm	1616 ¹⁾	1665 ¹⁾
WEIGHT					
2.1b	Truck weight without load, with maximum battery weight		kg	1866	2127
2.2	Axle loadings with nominal load & maximum battery weight, drive / load side		kg	1466 / 2000	1690 / 2438
2.3	Axle loadings without load & with maximum battery weight, drive / load side		kg	1306 / 560	1490 / 638
WHEELS, DRIVE TRAIN					
3.1	Tyres: PT = Power Thane, Vul = Vulkollan, P = Polyurethane, N = Nylon, R = Rubber drive / load side			Vul / Vul	Vul / Vul
3.2	Tyre dimensions, drive side		mm	250 x 105	250 x 105
3.3	Tyre dimensions, load side	ø	mm	85 x 70	85 x 70
3.4	Castor wheel dimensions (diameter x width)		mm	150 x 55	150 x 55
3.5	Number of wheels, load / drive side (x = driven)			1 x + 2 / 4	1 x + 2 / 4
3.6	Track width (center of tyres), drive side	b10	mm	706	706
3.7	Track width (center of tyres), load side	b11	mm	402	392
DIMENSIONS					
4.2a	Height with mast lowered	h1	mm	see tables	see tables
4.2b	Height	h1	mm	see tables	see tables
4.3	Free lift	h2	mm	see tables	see tables
4.4	Lift height	h3	mm	see tables	see tables
4.5	Height with mast extended	h4	mm	see tables	see tables
4.6	Initial lift	h5	mm	-	-
4.7	Height to top of overhead guard	h6	mm	2110	2110
4.8	Seat- or stand height	h7	mm	966	966
4.10	Height of support legs	h8	mm	80	83
4.15	Fork height, fully lowered	h13	mm	87	90
4.19	Overall length	l1	mm	2189 ¹⁾	2238 ¹⁾
4.20	Length to fork face	l2	mm	1019 ¹⁾	1068 ¹⁾
4.21	Overall width	b1/b2	mm	1010	1010
4.22	Fork dimensions (thickness, width, length)	s/e/l	mm	70 / 180 / 1170	70 / 195 / 1170
4.25	Outside width over forks (minimum / maximum)	b5	mm	570	570
4.32	Ground clearance at center of wheelbase, (forks lowered)	m2	mm	25	23
4.34a	Working aisle width (Ast) with 800 x 1200 mm pallets, load lengthwise	Ast	mm	2584 ²⁾	2632 ²⁾
4.34b	Working aisle width (Ast3) with 800 x 1200 mm pallets, load lengthwise	Ast3	mm	2419	2466
4.35	Turning radius	Wa	mm	1819 ²⁾	1866 ²⁾
PERFORMANCE					
5.1	Travel speed, with / without load		km/h	10 / 10	9 / 9
5.2	Lifting speed, with / without load		m/s	0.16 / 0.32	0.12 / 0.22
5.3	Lowering speed, with / without load		m/s	0.44 / 0.41	0.33 / 0.30
5.8	Maximum gradeability with / without load		%	6.7 / 6.7	5.9 / 5.9
5.10	Service brakes (mechanical / hydraulic / electric / pneumatic)			Electric	Electric
ELECTRIC MOTORS					
6.1	Drive motor capacity (60 min. short duty)		kW	2.7	2.7
6.2	Lift motor output at 15% duty factor		kW	4.0	4.0
6.4	Battery voltage/capacity at 5-hour discharge		V/Ah	24 / 375 - 775	24 / 375 - 775
6.5	Battery weight		kg	305 - 620	305 - 620
MISCELLANEOUS					
8.1	Type of drive control			AC	AC

- 1) When SN/BC775 then add 104 mm
 2) Dimensions vary depending on battery carriage and mast type.
 Ast dimensions available in table on page 7.

AXIA EX

SBS16-20N2 Series SIT-ON STACKERS

1.6 - 2.0 - tonnes

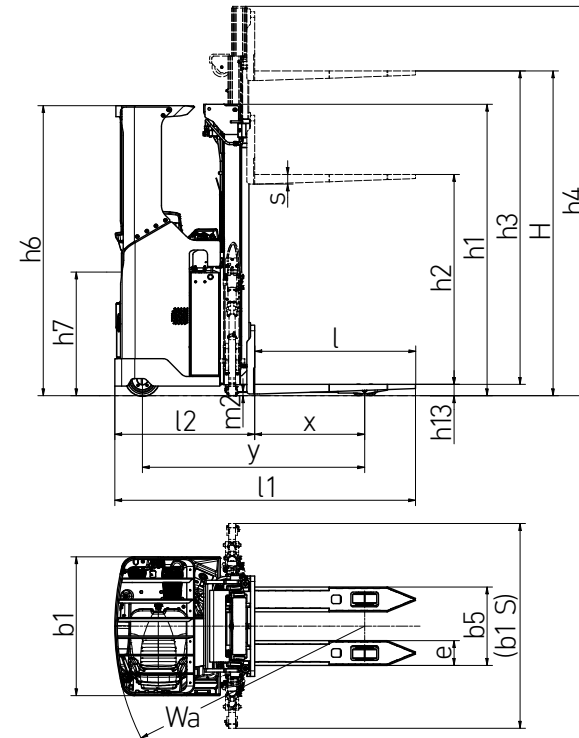

- Ast = Working aisle width
 Ast3 = Working aisle width (b12 < 1000 mm)
 $Ast = Wa + \sqrt{(l6 - x)^2 + (b12 / 2)^2} + a$
 Ast3 = Wa + l6 - x + a
 Wa = Turning radius
 l6 = Pallet length
 x = Load wheel axle to fork face
 b12 = Pallet width
 a = Safety clearance = 2 x 100 mm

VDI - PERFORMANCE & DIMENSIONS

CHARACTERISTICS				Mitsubishi Forklift Trucks	Mitsubishi Forklift Trucks
1.1	Manufacturer			SBS16N2I	SBS20N2I
1.2	Manufacturer's model designation			Battery	Battery
1.3	Power source			Sit-on	Sit-on
1.4	Operator type			1600	2000
1.5	Load capacity	Q	kg	600	600
1.6	Load center distance	c	mm	800	800
1.8	Load wheel axle to fork face (forks lowered)	x	mm	1661 ¹⁾	1720 ¹⁾
1.9	Wheelbase	y	mm		
WEIGHT					
2.1b	Truck weight without load, with maximum battery weight		kg	2015	2294
2.2	Axle loadings with nominal load & maximum battery weight, drive / load side		kg	1571 / 2045	1806 / 2488
2.3	Axle loadings without load & with maximum battery weight, drive / load side		kg	1411 / 605	1606 / 688
WHEELS, DRIVE TRAIN					
3.1	Tyres: PT = Power Thane, Vul = Vulkollan, P = Polyurethane, N = Nylon, R = Rubber drive / load side			Vul / Vul	Vul / Vul
3.2	Tyre dimensions, drive side		mm	250 x 105	250 x 105
3.3	Tyre dimensions, load side	ø	mm	85 x 70	85 x 70
3.4	Castor wheel dimensions (diameter x width)		mm	150 x 55	150 x 55
3.5	Number of wheels, load / drive side (x = driven)			1 x + 2 / 4	1 x + 2 / 4
3.6	Track width (center of tyres), drive side	b10	mm	706	706
3.7	Track width (center of tyres), load side	b11	mm	402	392
DIMENSIONS					
4.2a	Height with mast lowered	h1	mm	see tables	see tables
4.2b	Height	h1	mm	see tables	see tables
4.3	Free lift	h2	mm	see tables	see tables
4.4	Lift height	h3	mm	see tables	see tables
4.5	Height with mast extended	h4	mm	see tables	see tables
4.6	Initial lift	h5	mm	110	110
4.7	Height to top of overhead guard	h6	mm	2110	2110
4.8	Seat- or stand height	h7	mm	966	966
4.10	Height of support legs	h8	mm	87	87
4.15	Fork height, fully lowered	h13	mm	93	93
4.19	Overall length	l1	mm	2233 ¹⁾	2293 ¹⁾
4.20	Length to fork face	l2	mm	1063 ¹⁾	1123 ¹⁾
4.21	Overall width	b1/b2	mm	1010	1010
4.22	Fork dimensions (thickness, width, length)	s/e/l	mm	70 / 180 / 1170	70 / 195 / 1170
4.25	Outside width over forks (minimum / maximum)	b5	mm	570	570
4.32	Ground clearance at center of wheelbase, (forks lowered)	m2	mm	20	20
4.34a	Working aisle width (Ast) with 800 x 1200 mm pallets, load lengthwise	Ast	mm	2627 ²⁾	2685 ²⁾
4.34b	Working aisle width (Ast3) with 800 x 1200 mm pallets, load lengthwise	Ast3	mm	2461	2520
4.35	Turning radius	Wa	mm	1861 ²⁾	1920 ²⁾
PERFORMANCE					
5.1	Travel speed, with / without load		km/h	9 / 9	9 / 9
5.2	Lifting speed, with / without load		m/s	0.16 / 0.32	0.12 / 0.22
5.3	Lowering speed, with / without load		m/s	0.44 / 0.41	0.33 / 0.30
5.8	Maximum gradeability with / without load		%	26.6 / 26.6	25.6 / 25.6
5.10	Service brakes (mechanical / hydraulic / electric / pneumatic)			Electric	Electric
ELECTRIC MOTORS					
6.1	Drive motor capacity (60 min. short duty)		kW	2.7	2.7
6.2	Lift motor output at 15% duty factor		kW	4.0	4.0
6.4	Battery voltage/capacity at 5-hour discharge		V/Ah	24 / 375 - 775	24 / 375 - 775
6.5	Battery weight		kg	305 - 620	305 - 620
MISCELLANEOUS					
8.1	Type of drive control			AC	AC

- 1) When SN/BC775 then add 104 mm
 2) Dimensions vary depending on battery carriage and mast type.
 Ast dimensions available in table on page 7.

AXIA EX

SBS16-20N2I Series SIT-ON STACKERS MODELS WITH INITIAL LIFT

1.6 – 2.0 - tonnes

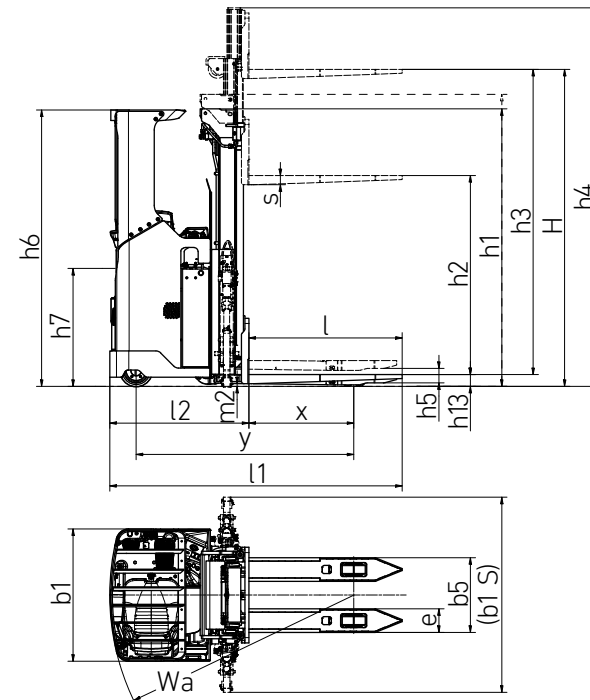

- Ast = Working aisle width
 Ast3 = Working aisle width (b12 < 1000 mm)
 $Ast = Wa + \sqrt{(l6 - x)^2 + (b12 / 2)^2} + a$
 Ast3 = Wa + l6 - x + a
 Wa = Turning radius
 l6 = Pallet length
 x = Load wheel axle to fork face
 b12 = Pallet width
 a = Safety clearance = 2 x 100 mm

MAST PERFORMANCE AND CAPACITY

AXIA EX SIT-ON STACKERS

SBS16-20N2

MAST TYPE	h3+h13 mm	h1 mm	h4 mm	h2+h13 mm
SBS16N2 / SBS20N2				
DEV	3600	2350	4105	1847
	4200	2650	4705	2147
	4500	2800	5005	2297
TREV	4800	2150	5332	1667
	5400	2350	5932	1867
	5700	2450	6232	1967
	6300	2650	6832	2167
	7000	2883	7532	2400

SBS16-20N2I

MAST TYPE	h3+h13 mm	h1 mm	h4 mm	h2+h13 mm
SBS16N2I / SBS20N2I				
DEV	3600	2355	4112	1853
	4200	2655	4712	2153
	4500	2805	5012	2303
TREV	4800	2155	5339	1673
	5400	2355	5939	1873
	5700	2455	6239	1973
	6300	2655	6839	2173
	7000	2888	7539	2406

DEV = Duplex with full free lift
 TREV = Triplex with full free lift
 h3+h13 = Lifting height
 h1 = Lowered mast height
 h4 = Raised mast height
 h2+h13 = Free lift

AST dimensions, VDI2198 (4.34a)				
BASIC CAPACITY, kg	1600		2000	
CHASSIS / BATTERY CARRIAGE	Junior / BC 465	Senior / BC 775	Junior / BC 465	Senior / BC 775
STANDARD MODEL	2584	2688	2632	2736
INITIAL LIFT MODEL	2627	2731	2685	2789

AST dimensions, Ast3 (4.34b)				
BASIC CAPACITY, kg	1600		2000	
CHASSIS / BATTERY CARRIAGE	Junior / BC 465	Senior / BC 775	Junior / BC 465	Senior / BC 775
STANDARD MODEL	2419	2523	2466	2570
INITIAL LIFT MODEL	2461	2565	2520	2624

STANDARD EQUIPMENT & OPTIONS

AXIA EX

SBS16-20N2(I) Series SIT-ON STACKERS

1.6 – 2.0 - tonnes

- = Standard
- = Option

	SBS16N2	SBS16N2I	SBS20N2	SBS20N2I
GENERAL				
Standard display incl. hour meter and battery indicator	●	●	●	●
Key switch entry	●	●	●	●
Electric power steering	●	●	●	●
Speed regulated lift motor and proportional valve for lowering	●	●	●	●
Tandem load wheels Vulkollan	●	●	●	●
Overhead guard	●	●	●	●
Adjustable armrest, right side	●	●	●	●
Adjustable steering wheel, all directions	●	●	●	●
Storage compartment under armrest and by left side of seat	●	●	●	●
Ergonomic fully adjustable seat	●	●	●	●
Battery rollers, plastic (steel rollers with bearings in Senior models)	●	●	●	●
Initial lift	-	●	-	●
Chill store design, down to -10°C	●	●	●	●
POWER SOURCE				
Li-ion batteries*	●	●	●	●
Lead acid batteries	●	●	●	●
ENVIRONMENT				
Cold store design, 0°C to -30°C	●	●	●	●
DRIVE AND LIFT CONTROLS				
Mini steering wheel with floating armrest	●	●	●	●
Midi steering wheel	●	●	●	●
Finger tip controls for lifting/lowering	●	●	●	●
Hands-free direction control (HFDC)	●	●	●	●
Hand operated direction control (HODC)	●	●	●	●
WHEEL OPTIONS				
Vulkollan	●	●	●	●
Tractothan	●	●	●	●
Super grip	●	●	●	●
OTHER OPTIONS				
Side stabilizers	●	●	●	●
Electric adjustable floor height, 70 mm	●	●	●	●
360 degree steering	●	●	●	●
Multifunction display incl. BDI and Hourmeter, PIN code login (100 codes) and graphic icons	●	●	●	●
High performance 8.0 kW AC hydraulic pump system	●	●	●	●
Load backrest	●	●	●	●
Key switch entry (in combination with Multi function display)	●	●	●	●
Laser positioning guide	●	●	●	●
Load weight indicator	●	●	●	●
Lift height indicator	●	●	●	●
Level assistance system (LAS)	●	●	●	●
Panoramic ProVision roof	●	●	●	●
12V DC Power Socket	●	●	●	●
5 V USB socket	●	●	●	●
Accessory rack	●	●	●	●
Writing desk incl. RAM C holder	●	●	●	●
Equipment holder RAM system size C	●	●	●	●
Equipment holder RAM system size C, 2 pcs	●	●	●	●
Equipment holder RAM size D	●	●	●	●
Working lights LED	●	●	●	●
Floor spot, red or blue	●	●	●	●
Increased drive speed, 12 km/h in driver compartment direction	●	-	●	-
Special RAL colour	●	●	●	●

* Li-ion battery option is available in selected regions.



Standard display



Storage compartment under armrest



Initial lift

WHEN RELIABILITY IS EVERYTHING...



AXIA
THE ALL ROUNDER

With a name that reflects its manoeuvrability, AXIA combines award-winning ergonomics with high performance and low maintenance features to deliver a complete warehouse support package.

Efficient, versatile and durable, AXIA is the perfect choice for every workplace.

Like any product bearing the "MITSUBISHI" name our materials handling equipment benefits from the tremendous heritage, huge resources and cutting-edge technology of one of the world's largest corporations – Mitsubishi Heavy Industries Group.

Engineering spacecraft, jet planes, power plants and more, MHI specialises in those technologies where performance, dependability and superiority decide your success or failure...

So when we promise you quality, reliability and value for money, you know it's a guarantee we have the power to deliver.

That's why every model in our award-winning and comprehensive range of lift trucks and warehouse equipment is built to a high specification – to ensure it keeps working for you. Day after day. Year after year. Whatever the job. Whatever the conditions.

YOU'LL NEVER WORK ALONE

As your local authorised dealer, we are here to keep your trucks working – through our extensive experience, our technical excellence and our commitment to customer care.

We are your local experts, backed by efficient channels to the entire organisation of Mitsubishi Forklift Trucks.

No matter where you are, we are close by – with the capability to meet your needs.

Discover how Mitsubishi Forklift Trucks give you more from your local authorised dealer or when you visit our website www.mitforklift.com

Performance specifications may vary depending on standard manufacturing tolerances, vehicle condition, types of tyres, floor or surface conditions, applications or operating environment. Trucks may be shown with non-standard options. Specific performance requirements and locally available configurations should be discussed with your distributor of Mitsubishi forklift trucks. We follow a policy of continual product improvement. For this reason, some materials, options and specifications could change without notice.

info@mitforklift.com

CESM2235 (10/22) © 2022 MLE

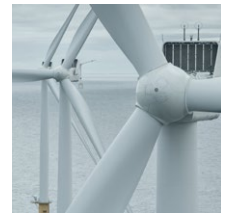

Mitsubishi Logisnext Europe B.V.
Hefbrugweg 77, 1332 AM Almere
The Netherlands
Tel: +31 (0)36 5494 411



mft2.eu/fb



mft2.eu/apps



mft2.eu/youtube



mft2.eu/facebook

